

# AXIOM<sup>®</sup>

---

---

---

---

## GP-100 TI II Graphic Printer

with

**DIRECT-CONNECT INTERFACE TO  
TEXAS INSTRUMENTS TI-99/4A<sup>®</sup>  
COMPUTER**

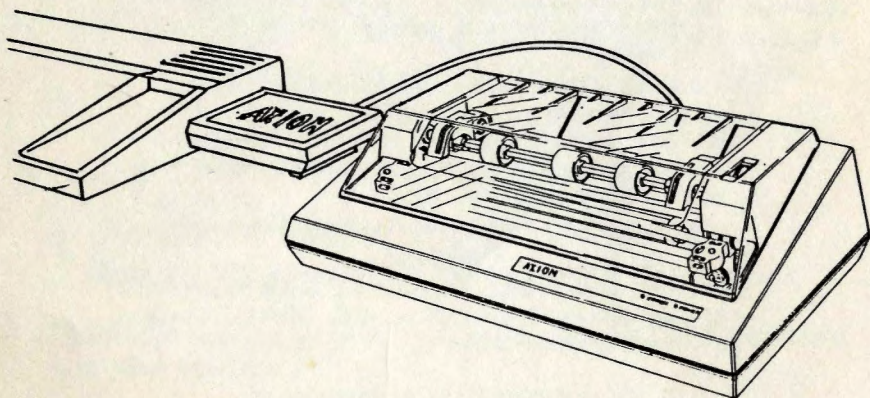

**USER'S GUIDE**

## Class B Computing Device

### INFORMATION TO USER

This equipment generates and uses radiofrequency energy and if not installed and used properly, that is, in strict accordance with the manufacturer's instructions, may cause interference to radio and television reception. It has been type tested and found to comply with the limits for a Class B computing device in accordance with the specifications in Subpart I of Part 15 of FCC Rules, which are designed to provide reasonable protection against such interference in a residential installation. However, there is no guarantee that interference will not occur in a particular installation. If this equipment does cause interference to radio or television reception, which can be determined by turning the equipment off and on, the user, is encouraged to try to correct the interference by one or more of the following measures.

Reorient the receiving antenna.

Relocate the computer with respect to the receiver.

Move the computer away from the receiver.

Plug the computer into a different outlet so that computer and receiver are on different circuits.

If necessary, the user should consult the dealer or an experienced radio/television technician for additional suggestions. The user may find the following booklet prepared by the Federal Communications Commission helpful:

*"How to Identify and Resolve Radio-TV Interference Problems".*

This booklet is available from the U.S. Government Printing Office, Washington, D.C. 20402, Stock Number 004-000-00345-4.

TI and 99/4A are trademarks of  
Texas Instruments Incorporated

## USER'S GUIDE

# AXIOM<sup>®</sup> GP-100 TI<sub>II</sub>

## TI-99/4A Direct-Connect GRAPHIC PRINTER

### How To Use This Manual:

- **Setting Up — Section 1, Page 2.**

You should read this section first to get to know your printer and how to load and adjust the paper and ribbon.

- **Hookup and Test — Section 2, Page 10.**

This section helps you to connect to the computer and run a simple printing check. Please read through this section at least once.

- **Print from Packaged Software — Section 3, Page 13.**

Describes normal operation: Device Name AXIOM, and notes for setting margin, etc.

*This may be as far as you ever need to go in this manual, but we think you will find the BASIC examples help you to understand what's really going on in a program.*

- **Printing from BASIC — Section 4, Page 17.**

With examples to step you through all the features.

- **Troubleshooting — Section 5, Page 27.**

Step by step guideline for curing your problems.

*Thanks for reading this far: we wish you success and satisfaction with your new printer.* downloaded and scanned [www.ti99iuc.it](http://www.ti99iuc.it)

# TABLE OF CONTENTS

	PAGE
<b>SPECIFICATIONS</b> .....	1
<b>1) SETTING UP</b> .....	2
1.1 External View and Parts Names .....	2
1.2 Switches and Controls .....	3
1.3 Printer Paper and How to Load It .....	5
1.4 Printhead Restrainer .....	7
1.5 Installing the Ink Ribbon .....	7
1.6 Head Stroke Adjustment .....	9
<b>2) HOOKUP AND TEST</b> .....	10
2.1 Connecting to your Computer .....	10
2.2 Self-Test .....	11
2.3 Cautions .....	12
<b>3) PRINTING WITH PACKAGED SOFTWARE</b> .....	13
3.1 Device Name .....	13
3.2 Using Interface Features .....	14
3.3 Using Printer Features .....	15
<b>4) PRINTING FROM BASIC</b> .....	17
4.1 OPEN, PRINT #, CLOSE .....	17
4.2 LIST .....	17
4.3 Device Names and Options .....	18
4.4 Features by Control Characters .....	19
Carriage Return and Linefeed	
Double Width Characters	
Overprinting	
TAB, comma, POS	
Dot Addressable Graphics	
Repeating Dot Graphics Patterns	
<b>5) TROUBLESHOOTING GUIDE</b> .....	27
5.1 Maintenance .....	27
5.2 Error Codes .....	27
5.3 Troubleshooting .....	28
5.4 Jumper Options .....	31
<b>APPENDIX A: Graphics Program in BASIC</b> .....	32
<b>APPENDIX B: ASCII and Control Code Table</b> .....	34

## SPECIFICATIONS

- A. Print method . . . . . Impact dot matrix print  
(SEIKOSHA's uni-hammer method)
- B. Character matrix. . . . . 5 x 7 dot matrix standard, with double  
width capability
- C. Characters . . . . . Full upper/lower case characters,  
numerals and symbols
- D. Graphics . . . . . Dot addressable. 7 vertical dots per  
column, max 480 columns
- E. Character codes . . . . . 7- or 8-bit ASCII
- F. Character size . . . . . Height: 7 dots (2.82 mm)  
Width: 5 dots (2.11 mm) + 1 dot space
- G. Print speed. . . . . 30 characters/sec (left to right,  
unidirectional)
- H. Max. number of . . . . . 80 columns  
columns
- I. Character spacing . . . . . 10 characters/inch
- J. Linefeed spacing. . . . . 6 lines/inch. . . . . Character mode  
9 lines/inch. . . . . Graphic mode
- K. Linefeed space. . . . . 5 linefeeds/sec . . . . . Character mode  
7.5 linefeeds/sec . . . . . Graphic mode
- L. Paper feed . . . . . Pin feed with manual advance
- M. Paper width . . . . . 4.5 to 10 inches acceptable
- N. Multiple copies . . . . . 2 including original
- O. Inked ribbon . . . . . Single color, inked roller built-in  
cassette type, part #5086.020
- P. External dimensions 234.5D x 420W x 136H (mm)  
8 $\frac{3}{8}$ " x 16 $\frac{1}{2}$ " x 5 $\frac{3}{8}$ "
- Q. Weight. . . . . Approximately 4.5 kg. (10 lbs.)
- R. Interface . . . . . Direct-connect to TI-99/4A
- S. Power . . . . . 117 VAC  $\pm$  10%, 50/60 Hz.
- T. Power consumption 20 W printing, 10 W standby
- U. Environmental . . . . . 5-40°C, 20-80% R.H.

# 1) SETTING UP

## 1.1 EXTERNAL VIEW AND PARTS NAMES

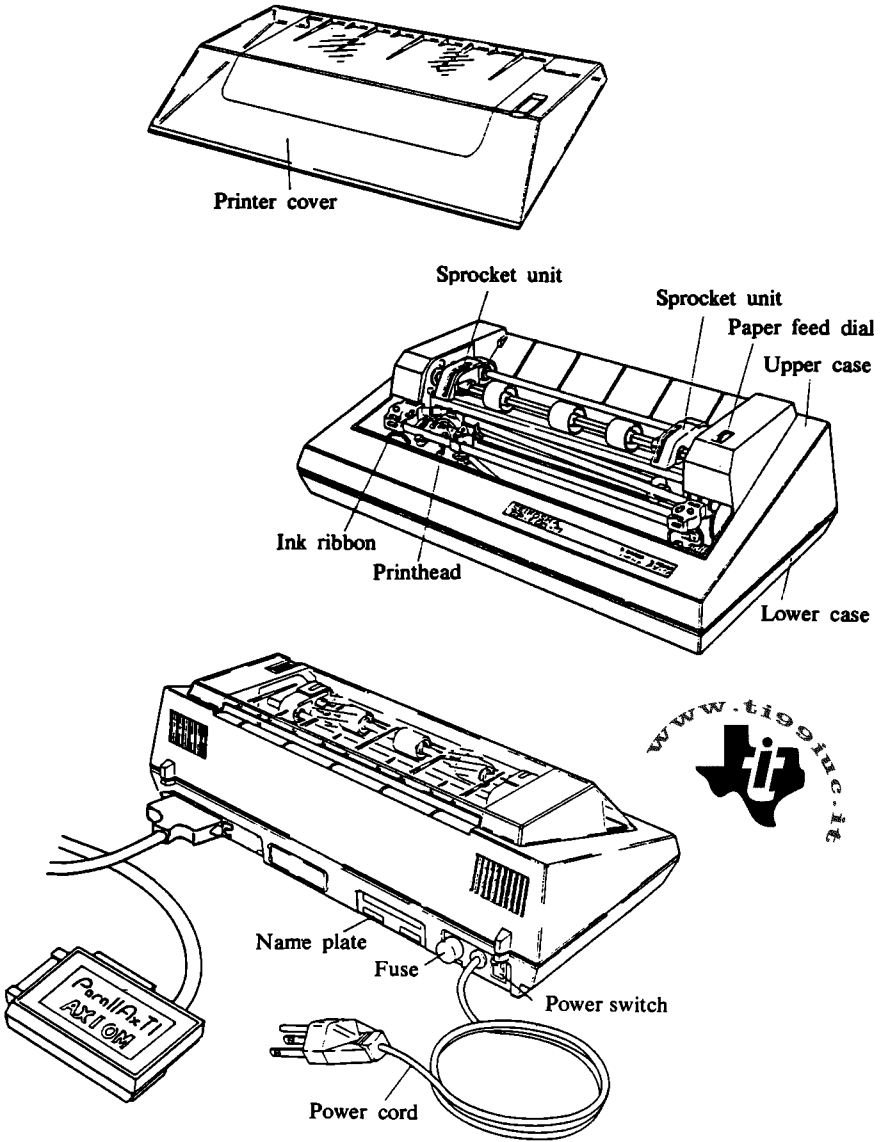

## 1.2 SWITCHES AND CONTROLS

### 1. Power switch

The power switch is located at the lower left on the back of the printer.

#### (NOTES)

Turn OFF power to printer and computer when connecting or disconnecting the interface.

DO NOT TURN OFF printer power while you are running a program or you may "hang up" the computer. Try to use the CLEAR key (FCTN 4) to stop the printer.

When the power switch is turned "ON", the printer goes through an initialization sequence that lasts about 1.5 seconds and in which the print head makes two movements.

When you turn "OFF" the printer, you should wait a few seconds before turning it "ON" again, to allow the electronics to reset properly.

### 2. Lamps



**POWER:** This lamp comes on when the power switch is turned "ON", and is off when power is "OFF".

**ERROR:** This lamp comes on when there is some malfunction of the printer. When an error condition arises, it can be cleared only by turning the power switch off and then on again.

### 3. Printer cover

The printer cover keeps dirt and dust from getting into the printer and also helps keep sound from getting out. The printer cover should always be set properly in place when using the printer.

#### 4. Paper feed dial

The paper feed dial is used to feed paper through manually. The smallest increment of paper movement is 1/18 of an inch.

Paper cannot be fed through in the reverse direction.

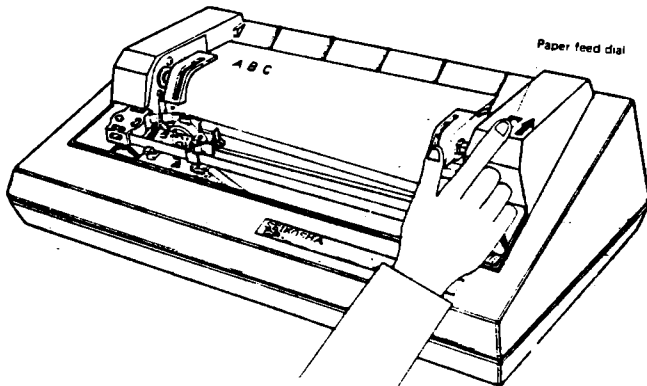

#### 5. Fuse

The primary side of the power supply is fuse protected. The fuse is located on the back of the printer to the side of the power switch. There are fuses in the internal power supplies of the printer, but these should only be changed by an experienced service person.

#### 6. Interface

The interface circuit which connects to your TI-99/4A is housed in a plastic box with a cable attached to the printer. Connection and operation are described in Section 2.



### 1.3 PRINTER PAPER, AND HOW TO LOAD IT

#### 1. Printer paper

Use the following types of paper for the printer.

Paper width	4.5 - 10 inches (115 - 254 mm) (4 - 9.5 inches between sprocket holes)
Paper weight	● 15 pounds (15#) in USA is recommended
Multiple part paper 2 including original	● Total thickness 0.12 mm or less

#### 2. Loading the paper

Paper should be loaded into the printer after power is turned OFF.

- (1) Remove the printer cover.
- (2) Lift up the paper holders on the left and right.
- (3) Adjust the sprocket such that the distance between them matches the holes in the paper.

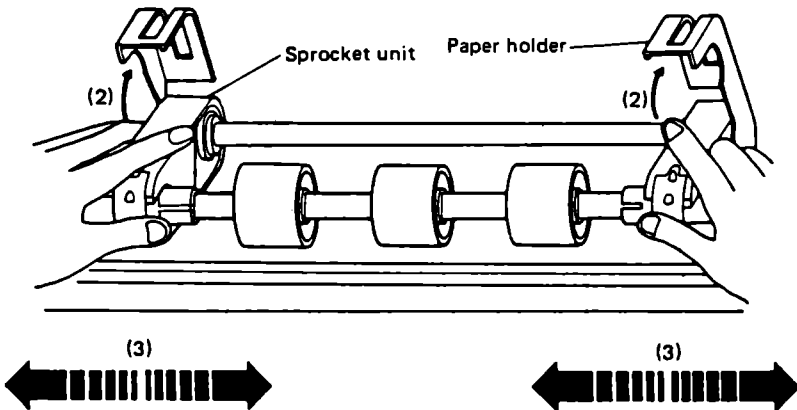

When using 10 inch width paper, the pin holes on the left side of the paper should be set about 14 mm (approx. 1/2") from the left side of the printer in order to center the printing on the page.

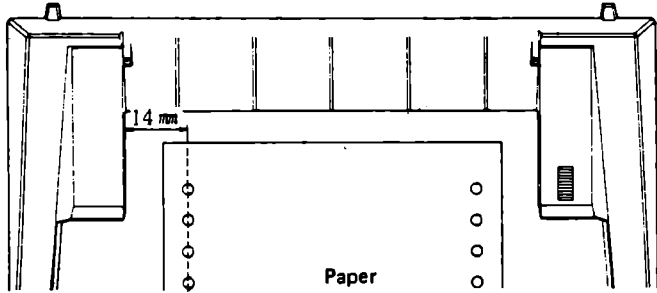

- (4) Feed the paper into the printer from the back.
- (5) When the paper extends out past the area where printing takes place (the space between the ink ribbon and the platen), set it in place on the pins.
- (6) Lower the paper holders into place.

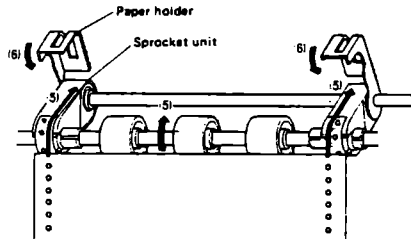
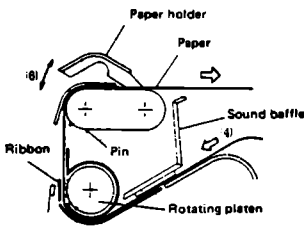

Does the paper feed straight into the sprocket units? Is there any resistance as the printer tries to pull paper through? These points are important since the linefeed mechanism will not operate properly unless they are observed.

The paper stack should be placed in a position as shown in diagram (B) below. Placing it as shown in (A) is not good because there tends to be resistance as a new sheet is pulled off the stack.

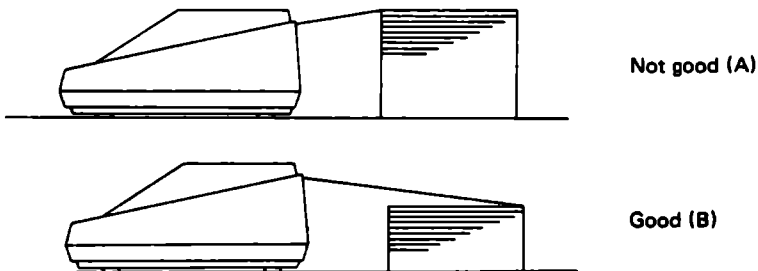

### 3. Print position

Printing starts at a position about 30 mm (1 1/8") from the left side of the printer.

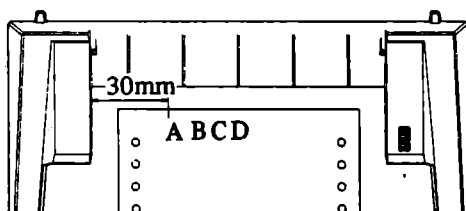

### 1.4 PRINTHEAD RESTRAINER

A black plastic tube is loosely fitted around the printhead guide bar to prevent the head from moving during shipping. Remove this restrainer before using the printer.

### 1.5 INSTALLING THE INK RIBBON

- (1) The ink ribbon is a special cassette type for use exclusively with the printer. Part #5086.020

- (2) Place the ribbon cassette such that the tabs are facing toward the front.

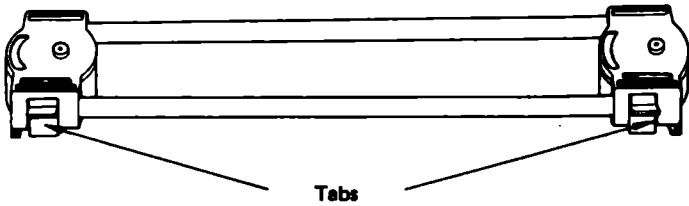

- (3) Remove the printer cover.  
(4) Install the ribbon cassette. The ribbon is installed by following steps ① , ② , ③ .

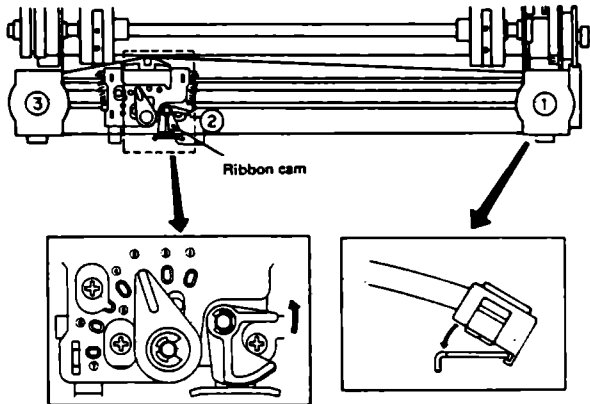

**(CAUTION)**

Make sure that the ribbon is not twisted.

The ribbon cannot be installed with the left and right cassette sections reversed.

Do not move the print head by hand. Trying to force it to move may damage the printer.

When installing or changing the ribbon, lifting up slightly on the inside of the cassette simplifies the operation.

## 1.6 HEAD STROKE ADJUSTMENT

The lever on the top of the print head is adjusted to suit the paper thickness and printing conditions. Adjust it for the thickness of paper being used and make sure that the lever clicks securely into place.

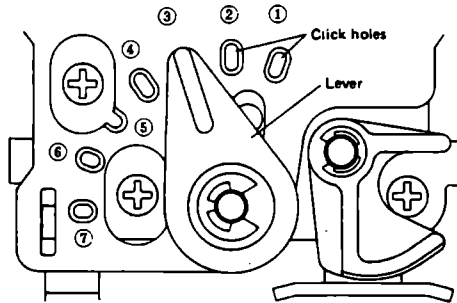

Turning the head adjustment lever in the clockwise direction [toward (1)] causes the printing to become darker.

Turning the head adjustment lever in the counter-clockwise direction [toward (7)] causes the printing to become lighter.

### (CAUTION)

It is not good to have the print hammer directly strike the platen or strike the platen through the ribbon alone.

## 2) HOOKUP & TEST

### 2.1 CONNECTING THE GP-100 TI II TO YOUR COMPUTER.

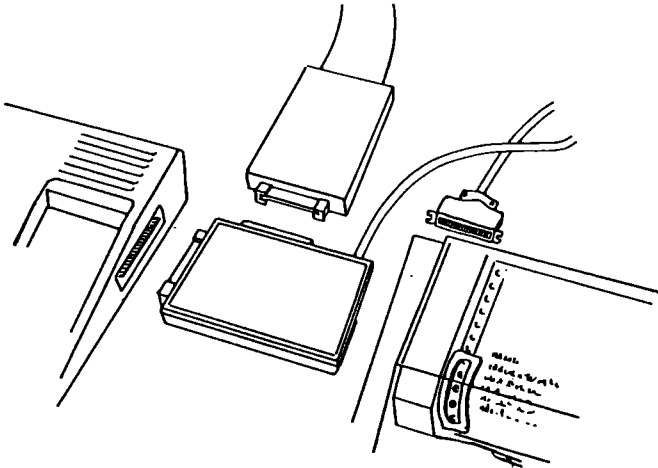

- (a) Turn OFF power to both printer and computer.
- (b) Open the access door to the right side of your TI-99/4A keyboard unit. This exposes the edge of a circuit card which brings signals in and out of the computer.

If you are using the Solid State Speech Synthesizer, or have other "sidecar" modules already plugged into this side of your keyboard unit, then open the access door on the right side of the last one of them.

If you are using the TI-99/4A Peripheral Expansion System, then you should disconnect its heavy cable connector from the right side of the keyboard unit, to expose the circuit card edge. You will then reconnect the Peripheral Expansion Cable to the back of the Printer Interface card (after removing the black protective insulation from the protruding edge of the interface circuit board).

- (c) Push the card-edge connector of your Printer Interface box firmly onto the exposed circuit card edge. Be sure the interface box is the right way up, with its foot facing down to support it.
- (d) Make sure PAPER and RIBBON CARTRIDGE are loaded in printer.

- (e) Turn the power **ON** to the **printer first**, before power is applied to the keyboard. The printer also supplies power to the interface box.

Finally turn on the Peripheral Expansion System (if used) and the keyboard console. If you hold down the space bar when powering-on the keyboard, you will start a Self Test routine, described in the next section.

### **(CAUTION)**

Never connect or disconnect the interface while power is applied to it or the computer.

The sequence of turning on and off power to the TI-99/4A and the GP-100 TI II is not important, but if printer power is turned off while you are printing, you will probably “hang up” the computer and have to turn it off to restart properly. This loses the program and data you were running: so you should try to use the **CLEAR** key (FCTN 4) to stop the printer.

## **2.2 SELF TEST**

When you have loaded the ribbon and paper, and have made the proper connections to the computer, then you can check out the printer by activating “Self Test”.

Hold down the **SPACE BAR** on the computer keyboard when you turn on the power. After a few moments of initialization, your GP-100 TI II will begin printing out all its standard characters in sequence, and will continue until the space bar is released. At the end of the test, the printer will perform a linefeed (to clear its buffer) and then start normal operation as if there had been no test routine.

If you do not get the printout expected, then you should re-check all the connections and try again before going to the troubleshooting hints in Section 5.

## 2.3 CAUTIONS

- Wait at least two seconds to turn on the power after it is turned off, otherwise the Printer will not be initialized properly. The same applies to TI-99/4A keyboard unit.
- Never place the Printer where it is exposed to direct sunlight, or excess dust or humidity.
- Never apply power while you are plugging in or unplugging an input connector.
- Try not to turn off the Printer power while it is printing.
- Do not turn off the power to the Printer while the keyboard is on, or your program may be lost.
- Never try to move the print head manually, whether the power is on or off.
- Do not stop the print head motion while it is printing.
- Do not print without paper and/or ribbon because the print head and platen might be damaged.
- If you drop a foreign object into the printer, turn OFF the power before removing it. Do not turn power back on until the power to the keyboard is also off. Then make sure the printer has initialized properly.
- Do not subject the Printer to temperatures below 5°C or above 40°C during operations, or to a sudden change in temperature.
- Regarding the printing duty:  
In graphic mode, using patterns with too much dot density will wear out the print head faster. We recommend that you use patterns whose dot density is equal to that of ordinary alphanumeric. The continuous printing of high dot density patterns may adversely affect the longevity of the print head.
- Unplug the power cord before trying to take off the outer case of the printer or the interface.
- Be sure to minimize the 'drag' of the paper. When using the multipart forms, you may need to position the paper supply close to the level of the printer, not on the floor.



### 3) PRINTING WITH PACKAGED SOFTWARE

There are many programs commercially available for Word Processing or Business Calculations which are designed to be used with a printer. They should all run at once with your GP-100 TI II, because these use standard file structure and commands.

#### 3.1 DEVICE NAME

The DEVICE NAME is AXIOM or PIO for opening files to send output to the printer. You will normally be asked questions by the program, such as . . .

WHERE DO YOU WANT LISTING?

1 SCREEN

2 SOLID STATE PRINTER

3 RS232 INTERFACE

4 OTHER

YOUR CHOICE?

You will select OTHER by typing

4

and the program will prompt . . .

DEVICE NAME?

to which you reply by typing:

AXIOM

and this should be all that you need for directing printout through the interface to your printer.

Once properly addressed, the interface will transfer ALL bytes through to the printer unchanged; and so use of control codes for the printer depends only on the flexibility of the software.

If the program does not allow you to enter the interface device name in this way, there is still a good chance that it will generate the name "PIO" by itself, and give you the proper printout. If you come across a program which does not do this, *but* was expecting to send printout through an RS232 interface to a serial printer, then you can make a jumper modification so that the interface responds to "RS232". See Sections 5.4 and BASIC for a full description of this change and the limitations it imposes.

downloaded and scanned by: www.ti99iuc.it

### 3.2 USING INTERFACE FEATURES

When you are entering the DEVICE NAME, you can also select formatting options for line length, margin and linefeed spacing, and the number of bits (7 or 8) in each character sent to the printer.

For example, typing the DEVICE NAME

AXIOM.LF=2.MA=10

will give double spaced (2 linefeeds) printout with a ten character margin. Codes for each option start with a period, and they can be combined in any order.

- . CR            No automatic Carriage Return/Linefeed.  
                 Overrides . LF = settings
- . LF            No automatic paper advance — for  
                 overprinting
- . LF = 2        (or 3 etc.) for double spaced (triple, etc.)
- . LL = 40       Gives 40 character line length; see notes in  
                 BASIC section. Default value is 80.
- . MA = 5        Gives 5 space margin, MA value must be  
                 less than LL value.
- . DA            Passes only 7 bits of character to printer.

If the program asks you for LINE LENGTH? or WIDTH? you will normally enter 80 for 80 column printout. When you are trying to format your print with a margin and fewer characters per line, you may have to give the new value by entering it for both WIDTH? and also . LL = .

## CR and LF

These are the symbols for Carriage Return (CR) and Linefeed (LF). The CR and LF have traditional meanings (CR = return to left margin without advancing paper; LF = advance paper without returning to margin) which are seldom used today. The GP-100 TI II uses the most common convention: CR prints and returns to the left margin without advancing paper; LF prints, returns to left margin and advances paper.

The TI-99/4A operating system normally generates both CR and LF in a way compatible with the printer; but if some software produces unintended overprinting or double spacing, then you can try to correct it with the . LF = added to device name.

### 3.3 USING PRINTER FEATURES

The sections on BASIC and the appendix list the special printout features which can be called on by sending control code sequences to the printer. Please try reading through these sections for detailed explanations on how to use them. Here we are listing some of them for convenience only.

TYPE in	CODE	Decimal Value	FUNCTION
CTRL-M	CR	13	Carriage Return for overprinting
CTRL-N	SO	14	Start double width characters
CTRL-O	SI	15	Start normal characters
CTRL-P	POS	16	Followed by two digits defines character position

The rest of the control sequences will be very difficult to insert into packaged software, although the principles are the same as for those shown.

#### What are Control Codes, anyway?

There is a standard code for sending text to micro-computers, called ASCII (American Standard Code for Information Interchange). The codes are not really very different from the old Morse Code, except that each character from the old Morse Code, except that each character is represented by a group of seven 1's or 0's (bits) instead of patterns of long or short. You can make 128 different patterns out of 7 bits, which computer

people number from 0 to 127. Of these, 32 to 126 are for alphabets, numbers, punctuations; and 0 to 31 are reserved for control functions. Finally, 127 is called DELETE and is usually ignored but is printed as a space by the GP-100 TI II. You have already heard about Linefeed and Carriage Return which have codes 10 and 13; the most important for special features is ESCAPE code number 27.

### **What happens to the 8th bit when ASCII only uses 7?**

Even 16-bit computers like your TI-99/4A manipulate text in 8-bit bytes: so there is indeed an extra bit for each character. To print ASCII most printers require this bit to be zero; if it is high the GP-100 TI II will print special symbols and foreign characters. Most packaged programs will take care of this extra bit for you; but if you find printout with unexpected strange characters, you should try entering DEVICE NAME? as AXIOM.DA so that the extra bit is forced to zero.

### **Can you enter Control Codes from the keyboard?**

Probably — it depends on the software. The FCTN and CTRL keys can be combined with other keys to generate control codes, and your Parallax interface is guaranteed to pass them through unchanged to the printer. But some programs are designed to check your typing and throw away control codes — you will just have to experiment, and as a last resort contact the software designers if you cannot make it work. Try it on a ‘dummy’ run of the program.

A table of Function and Control Key Codes is shown in the TI-99/4A User's Reference Guide, Appendix III-2. You will see that the computer can interpret each keystroke in more than one way (BASIC mode and PASCAL mode). An examples, ESC is typed CONTROL . (hold down CTRL key and type a period before releasing CTRL) but is given either of two numeric values, 155 or 27. These are different because of that ‘extra bit’ we discussed, and the value will depend on details of how the program was written: you may be able to force the 27 by using Device Name AXIOM.DA which strips the extra bit. While experimenting, you should use a simple control code before going to the complex sequences. We suggest CR (CTRL-M) or LINEFEED (CTRL-J) which are both easy to recognize on a printer.

## 4) PRINTING FROM BASIC

### 4.1 OPEN, PRINT #, CLOSE

Try typing in the following simple program, and running it (we assume you are familiar with writing simple BASIC programs):

```
10 OPEN #1:"AXIOM"  
20 PRINT #1:"Now I have a Printer!"  
30 CLOSE #1
```

Now I have a Printer!

Let us give brief comments on each line of the program:

- 10 OPEN #1:"AXIOM" Opens File #1, and tells the computer that File #1 talks to the device named **AXIOM**
- 20 PRINT #1:"Now... Sends "Now I have a Printer!" and a carriage return/linefeed to the printer.
- 30 CLOSE #1 Closes the file you defined in line 10. You cannot use the "PRINT #1:" command again until you open a new File #1.

#### (NOTE)

The commands and the DEVICE NAME **AXIOM** are all in Upper Case (capitals), and you would get a message "I/O ERROR 00" if you enter lower case by mistake. Other Device Names and options are listed below.

### 4.2 LIST

To list a BASIC program from memory to the printer, the command is as follows:

```
LIST "AXIOM" 
```

The listing of the program in memory will be output to the printer. (Just a reminder about ENTER after commands: we will not repeat it every time.)

```
LIST "AXIOM" : 20 - 30
```

will list out the specified section of your program.

The Interface will support OPEN, PRINT #, CLOSE, and LIST. Other operations such as SAVE, OLD, INPUT will cause an error message to be generated.

Depressing "CLEAR" (holding down FCTN and typing 4 will terminate the output to the printer. A message will be printed

on the screen “\*I/O ERROR 36 IN...” when the program breaks.

### 4.3 DEVICE NAMES AND OPTIONS

**AXIOM** and **PIO** are both valid device names for accessing your printer, and either may be used according to your preference. The optional ‘software-switch-settings’ listed below can also be added to either name.

You may come across a program written specifically for a serial printer attached to one of the older serial I/O modules. This would have a device name such as **RS232** or **RS232/1** or **RS232/2**. If you cannot change the name, then you can modify the Axiom interface to respond to the **RS232** names as well as **AXIOM** and **PIO**. This modification is described in the last section, Troubleshooting and Jumper Options.

#### Software Switch Settings

There are a number of features which you can select by adding special symbols to the **DEVICE NAME**.

**.DA**            8th bit of input character is ignored  
**.CR**            No automatic CR or LF at end of line  
                  Overrides **.LF** settings  
**.LF**            No automatic LF at end of line (just CR)  
**.LF = 1-9**      Multiple spaced lines with 1-9 linefeeds  
**.LL = 1-80**    Line length 1 to 80 characters  
**.MA = 0-79**    Left margin setting; less than **.LL** value

These settings may be added in any order to the device name. For example:

```
10 OPEN #1: “AXIOM . MA=20 . LL=48 . LF=2”
```

will produce printout with a 20 column left margin, and then 28 columns of print, all double spaced. It will remain in force for every **PRINT #1** statement until you **CLOSE #1**.

These software switch options may also be used with **LIST**.

```
LIST “AXIOM.LL=28”
```

will give a listing that has the same format as the screen.

## Code Conversion

Apart from the 7/8 bit selection (.DA), ALL codes are transmitted to the printer unmodified by the interface. This means that you can work directly from this manual for the control codes to set up the printer. The BASIC function CHR\$( ) will create any code needed.

### 4.4 PRINTER FEATURES SELECTED BY CONTROL CHARACTERS

As well as the margin setting, line length, and line spacing described above, the GP-100 TI II has a number of powerful features to give you detailed control over the printout. Characters can be printed normal size or double-width, and can be overprinted to create boldface before advancing the paper. Tables can be laid out effortlessly with the 'position' function; and in fact the Graphics mode allows you to control the placement of each and every dot on the paper.

All of these features are called up by sending sequences of control codes to the printer. The Appendix has a table of ASCII values and a brief list of the control codes and their effect when sent to the printer. You will generally send these codes with the CHR\$(N) function where N is the (decimal) value of the code to be sent.

You can also enter control codes between the quote marks of a literal (or string) you are sending out with a PRINT # statement. The control codes are typed in as described in Section 3.3 and in the TI-99/4A User's Reference Guide, Appendix III-2. These can speed up your typing by replacing the whole of ";CHR\$(N);" with a single keystroke — but they are very hard to edit or even review at a later date. Often you can simplify part way by defining D\$=CHR\$(14) and S\$=CHR\$(15) using D\$ and S\$ for double and single sized characters.

### Carriage Return & Linefeed

The TI-99/4A generates the control codes CR and LF whenever you end a PRINT # statement without a semicolon (or comma). That is the conventional way to tell the printer to print the line and return the printhead to the left margin (CR) and advance the paper (LF). You saw in Section 4.3 how to the CR/LF, or send out CR only or multiple LF's.

You should note that the TI expects to send out blocks of text of no more than 80 bytes (characters or control codes) per block. If you are overprinting or otherwise sending many lines to the printer with semicolons at their end (no CR/LF) then the operating system will interrupt the printout after every 80 bytes and send out the CR/LF — unless you have selected the .LF or .CR options.

## Double Width Characters

Sending CHR\$(14) to your printer will cause all text to be printed in double width characters until you send CHR\$(15) — or until you turn the printer off and start again. Try typing in and running this program.

```
10 OPEN #1:"AXIOM"  
20 PRINT #1:"SINGLE & ";  
30 PRINT #1:CHR$(14);"double";  
40 PRINT #1:CHR$(15);" width"  
50 CLOSE #1
```

```
SINGLE & double width
```

You could have combined lines 20, 30 and 40 into a single (long) PRINT # statement: we have separated it to emphasize the effect of these control codes.

## Overprinting

Your printer can be told to print a line and return to the left margin (without advancing the paper) by sending it CHR\$(13) or CHR\$(20). The first of these is CHR\$(13) = CR = Carriage Return and is the one most commonly used for printing without paper advance, so we will use it in our example:

```
10 OPEN #1:"AXIOM"  
20 PRINT #1:"OVERPRINT";CHR$(13);  
30 PRINT #1:"OVER";CHR$(13);"OVER"  
40 CLOSE #1
```

```
OVERPRINT
```

Note how we have put a semicolon (;) after each string to be printed until the second "OVER" of line 30. The semicolon keeps the TI-99/4A from adding its own CR/LF after print



statements, so we do not advance the paper until we are ready for it. (LF = Linefeed, or paper advance)

We could also have protected our text against unwanted linefeeds by changing line 10 to read

```
10 OPEN #1:"AXIOM.LF"
```

This 'software switch' option keeps the 99/4A from sending out LF at the end of print statements which don't have semicolons. It makes overprinting easy — usually too easy! With the .LF option you must explicitly demand a paper advance to get one at all. For this you use LineFeed = LF = CHR\$(10), and line 30 must now read:

```
30 PRINT #1:"OVER";CHR$(13);"OVER";CHR$(10)
```

This suggests an even simpler way to write the same program, using the CR-only provided by the .LF option.

```
10 OPEN #1:"AXIOM.LF"
20 PRINT #1:"OVERPRINT"
30 PRINT #1:"OVER";"OVER";CHR$(10)
40 CLOSE #1

OVERPRINT
```

There is one situation where you must use the .CR option (do not send out either CR or LF at the end of a block). The 99/4A expects you to send out text to a printer in blocks no longer than 80 characters, and will send out an unexpected CR/LF if you put too many strings together with semicolons. Here is an example:

```
10 OPEN #1:"AXIOM"
20 FOR I=1 TO 10
30 PRINT #1:"OVERPRINT";CHR$(13);
40 NEXT I
50 PRINT #1
60 CLOSE #1

OVERPRINT
OVERPRINT
```

You could partially correct this by changing the block length in the open statement, to read:

```
10 OPEN #1:"AXIOM",VARIABLE 132
```

but the cure will only work in special cases. The proper way out of the predicament is to take control completely as shown below:

```
5 REM N5 B
10 OPEN #1:"AXIOM.CR"
20 FOR I=1 TO 10
30 PRINT #1:"OVERPRINT";CHR$(13)
40 NEXT I
50 PRINT #1:CHR$(10)
60 CLOSE #1

OVERPRINT
```

## TAB( ), comma, and POS

The TAB function works with your printer just as well as it does on the screen, and you should refer to the 99/4A User's Reference Guide for a detailed description. If you enter OPEN #1:"AXIOM.LL=28" then your printout should match the screen exactly. Similarly the use of commas to separate your screen display into blocks of 14 characters (half the screen) will separate your printout into blocks of 14 characters across the page.

```
10 OPEN #1:"AXIOM"
20 PRINT #1:TAB(10);"A";TAB(20);"B"
30 FOR I=1 TO 5
40 PRINT #1:"123456789 ";
50 NEXT I
60 PRINT #1:,"X","Y","Z"
70 CLOSE #1
```

```
123456789 A 123456789 B 123456789 123456789 123456789
X Y Z
```

Your printer also has built-in positioning codes, POS = CHR\$(16), and ESC POS = CHR\$(27) CHR\$(16).

The first, POS, is followed by two digits telling which column to print in: the columns are numbered from 00 to 79 (always two digits; and note the counting from zero rather than one). The POS function is rather like TAB, except that you can set the POS to a higher number, give a CHR\$(13); and then POS to a lower number without advancing the paper. TAB is counted by the 99/4A operating system and won't let you do this.

```
10 OPEN #1:"PIO"
20 REM "PIO" works just like "AXIOM"
30 PRINT #1:CHR$(16);"10A";CHR$(13);CHR$(16);"05B"
40 PRINT #1:TAB(10);"A";CHR$(13);TAB(5);"B"
50 CLOSE #1
```

```
 B A
  A
 B
```

ESC POS allows you to position the start of your printing not just to a particular column, but to one of the six dot positions in it. You have probably noticed that each character is made up of dots and that the dot matrix for each is 5 horizontal by 7 vertical, with a 6th horizontal dot separating the characters. Counting 6 dots per character column, times 80 columns, give 480 dot positions. You send out the dot-position number 0 to 479 not by text characters ("000" to "479") but by CHR\$. This is best for cases where the dot position is the result of a calculation (you would have to convert the number into a string of the correct length), but is complicated by CHR\$ only going up to 255. The solution is to divide the number into two parts and always send two bytes (CHR\$'s) which are the number of 256's, and then the remainder when you take off any 256's. It is much easier to see in an example.

```
10 OPEN #1:"AXIOM"  
20 FOR I=254 TO 257  
30 N1=INT(I/256)  
40 N2=I-256*N1  
50 PRINT #1:CHR$(27);CHR$(16);CHR$(N1);CHR$(N2);I  
60 NEXT I  
70 CLOSE #1
```

```
254  
255  
256  
257
```



Here is a program to print out your graphic triangle:

```
10 OPEN #1:"AXIOM"  
20 PRINT #1:CHR$(8)  
30 FOR I=1 TO 4  
40 PRINT #1:CHR$(129);CHR$(131);CHR$(133);CHR$(137);  
50 PRINT #1:CHR$(145);CHR$(161);CHR$(255)  
60 NEXT I  
70 PRINT #1:CHR$(15)  
80 CLOSE #1
```

4444

Don't forget the CHR\$(15) to get out of graphics: something you will also have to use if you stop a graphics routine with the CLEAR (FCTN 4) key. If you ever try to print some text or a listing and find that there are paper-feeds but no print: then the first thing to try is sending CHR\$(15) — or initializing the printer by power off and on again.

## Repeating Dot Graphics Patterns

When the same dot pattern is to be repeated many times on a line, you can simplify the program and speed up the printout by using a special control code sequence. You must first have entered the graphics mode with CHR\$(8); then you send the sequence of CHR\$(28) followed by CHR\$(number of repeats) and CHR\$(dot pattern with 'flag'). This is particularly useful for bar charts:

```
10 OPEN #1:"AXIOM"  
20 FOR I=1 TO 5  
30 READ D  
40 PRINT #1:D;" ";  
50 PRINT #1:CHR$(8);CHR$(255);  
60 PRINT #1:CHR$(28);CHR$(D);CHR$(193);  
70 PRINT #1:CHR$(255);CHR$(15)  
80 NEXT I  
90 CLOSE #1  
100 DATA 100,115,145,200,248
```

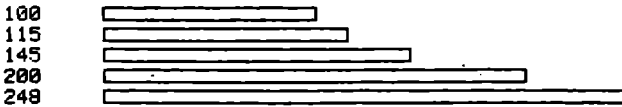

You have seen the amount of control you can have over your printout, with dot-addressable graphics and dot-column positioning of text. In Appendix B we give an example matching the dot graphics printout to the character definition capability of the 99/4A.

## 5) TROUBLESHOOTING GUIDE

### 5.1 MAINTENANCE

The GP-100 TI II needs little or no daily maintenance.

Use it with the same care as you give to other electronic equipment. Please observe the 'Cautions' listed in Section 2.3

#### Periodic Cleaning and Lubrication

Approximately every year the printhead guide bar should be cleaned and re-lubricated. This is the heavy bar supporting and guiding the printhead. Clean with alcohol using a lint-free cloth; lubricate with 2 drops of light sewing machine oil. This maintenance should be performed more often if the printer has unusually heavy usage, or operates in a dusty atmosphere.

### 5.2 ERROR CODES

Listed below are the error codes related to the operation of TI BASIC programs that use the AXIOM Interface Card.

#### OPEN:

CODE 00 — Device named in the statement or command cannot be opened: verify that you have typed name in upper case.

CODE 02 — The software switch option entry is in error, such as incorrect first two characters of an option, or illegal values.

CODE 06 — A hardware error occurred and the device cannot be opened.

#### PRINT:

CODE 36 — Some type of hardware error occurred. Also caused by pressing CLEAR to stop a pending or in-progress operation.

#### MISC. ERROR CODES:

CODE 43, 73, 83, 93 — Executing an illegal command.

## 5.3 TROUBLESHOOTING

If you have any troubles with printing, we suggest that you save the program you have been working on, and then try the Printer Self-Test. [Keyboard power OFF; waiting a few second; power ON while pressing space bar.]

- **Self Test is OK**

Problems are most likely to be in the software.

Did you use capital letters for the Device Name?

Does the printer need initialization? (Was it left in Graphics Mode?)

If printout had extra linefeeds and spaces, check the data block of 80 characters: try .LF or .CR.

- **Self Test prints, but wrong characters**

'Stuck' data bits give repeated patterns

...0123012389... instead of ...0123456789...

Are all connectors pushed in firmly?

Check cable from interface to printer for loose wires or damage.

- **No Self-Test: Screen shows TI logo, then menu**

Computer does not 'see' printer interface.

Probably not getting power to interface: check if cable to printer is plugged in correctly.

Possible hardware fault on ParallAx interface.

- **No Self-Test: Screen goes light blue**

Generally a problem between interface and printer.

Release space bar (end the Self-Test), and: —

Screen stays blank:

Probably printer was 'BUSY' or faulty.

Check the printer signal cable.

Possible hardware error or intermittent power.

Screen shows TI logo:

Printer not responding to interface signals.

Check the printer signal cable (STR not seen?)

Try to check printer with different data source.



- **No Self-Test: Screen dark. Hardware problem in some part of system**
  1. Check if keyboard unit is “hung up” in Reset. Keyboard power OFF; wait 5 seconds; Power ON again. Cured?
  2. Try hooking up only some parts of your system at a time. Start with keyboard console only, build up until fault appears.
  3. If problem appears only with interface then try checking the printer as below: if this does not help, then follow return policy on warranty card.

Here are some suggestions for checking out your printer.

<p>The printer does not print, and the power lamp does not light.</p>	<ol style="list-style-type: none"> <li>1) Power is not getting to the printer. <ul style="list-style-type: none"> <li>● Check the power cord and power switch.</li> </ul> </li> <li>2) The power line fuse may be blown. <ul style="list-style-type: none"> <li>● Replace it with exactly the same type fuse.</li> </ul> </li> <li>3) The +5 volt internal fuse may blown. <ul style="list-style-type: none"> <li>● Replace F1 inside printer with exactly the same type fuse.</li> </ul> </li> </ol>
<p>The printer does not print but the power lamp is lit. (You see printhead movement at power-on.)</p>	<ol style="list-style-type: none"> <li>1) The +20 volt internal fuse may be blown. <ul style="list-style-type: none"> <li>● Replace F2 inside printer with exactly the same type fuse.</li> </ul> </li> <li>2) The connection to the computer is not correct. <ul style="list-style-type: none"> <li>● Check to make sure that the cable that connects to the computer is connected correctly.</li> </ul> </li> <li>3) The ink ribbon is not properly installed. <ul style="list-style-type: none"> <li>● Properly install the ribbon.</li> </ul> </li> <li>4) Printhead may not have returned to left margin. <ul style="list-style-type: none"> <li>● Check for jammed paper, or see below.</li> </ul> </li> </ol>
<p>The printer is operating properly, but the paper is not feeding properly.</p>	<ol style="list-style-type: none"> <li>1) The paper is jammed in the printer. <ul style="list-style-type: none"> <li>● Remove the paper and reinsert it properly. Keep paper at proper level. Use proper weight of paper.</li> </ul> </li> </ol>
<p>The print is light or smeared.</p>	<ol style="list-style-type: none"> <li>1) The printhead stroke is not correct. <ul style="list-style-type: none"> <li>● Adjust the printhead lever to match the type of paper being used.</li> </ul> </li> <li>2) The ribbon is not properly installed. <ul style="list-style-type: none"> <li>● Properly install the ribbon.</li> </ul> </li> <li>3) The ink ribbon is old or is worn out. <ul style="list-style-type: none"> <li>● Replace it with a new ribbon.</li> </ul> </li> </ol>
<p>The ERROR lamp is lit.</p>	<ol style="list-style-type: none"> <li>1) An ERROR condition has occurred due to the detection of abnormal timing in a sensor. <ul style="list-style-type: none"> <li>● Turn power off and then back on again.</li> </ul> </li> </ol>
<p>ERROR lamp, or printhead does not return to left margin.</p>	<ol style="list-style-type: none"> <li>1) Print carriage sticking on guide bar. <ul style="list-style-type: none"> <li>● Clean carriage guide bar with alcohol and lubricate with 2 drops light sewing machine oil.</li> </ul> </li> </ol>

## 5.4 JUMPER OPTIONS (Only for special applications.)

The Parallax interface has two options which can be selected by changing jumper-wires on the interface card. The plastic box may be opened after the printer and computer are turned OFF and disconnected. A small Phillips-head screwdriver is needed to open the interface box; and soldering equipment for changing the jumpers. The location of these jumpers is shown in the diagram below.

The modifications should only be attempted by someone experienced at electronics assembly and soldering: don't try it you have any doubts!

J1: OPEN (no jumper) DEVICE NAME is "PIO" or "AXIOM"

J1: Jumper installed DEVICE NAME as above or "RS232", "RS232/1", or "RS232/2". Options .DA, .LL, .JA, .LF = are lost, replaced by .DA=7 or =8.

J2,3: As shipped CRU Address \$1B00

J2,3: Cut traces and jumper CRU Address \$1E00  
other 2 sides of square

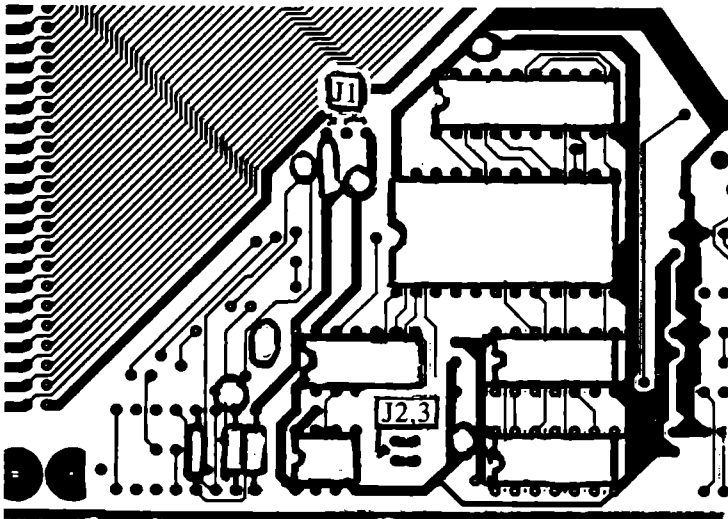

## APPENDIX A

```
100 REM
110 REM
120 REM ***** SET UP WORKSPACE
130 DIM A(9,8)
140 HEX$="0123456789ABCDEF"
150 LF$=CHR$(8)&CHR$(10)&CHR$(15)
160 SPC$=CHR$(15)&" "&CHR$(8)
170 PRINT
180 OPEN #1:"AXIOM.CR"
190 PRINT #1:CHR$(15);LF$
200 REM
210 REM ***** SET THE 'CHARACTERS'
220 REM
230 A$="1899FF3C3C222100"
240 B$="995A3C3C3C448400"
250 REM
260 REM ***** DISPLAY THEM FIRST BY BLOCKS
270 C$=A$
280 GOSUB 500
290 GA$=G$
300 C$=B$
310 GOSUB 500
320 GB$=G$
330 REM ***** AND THEN BY DOT PATTERNS
340 REM
350 CALL CHAR(128,A$)
360 CALL CHAR(129,B$)
370 PRINT #1:CHR$(8);
380 FOR I=1 TO 7
390 PRINT CHR$(128);" ";CHR$(129);" ";
400 PRINT #1:GA$;SPC$;GB$;SPC$;
410 NEXT I
420 PRINT ::
430 PRINT #1:CHR$(15):LF$:LF$:LF$:LF$
440 CLOSE #1
450 END
460 REM ***** (WE USE CHARACTERS 7 DOTS HIGH,
470 REM ***** YOU NEED MORE ARITHMETIC FOR 8)
480 REM
490 REM
```

```

500 REM      ***** SUBROUTINE USED FOR A$,B$
510 REM      TO PICK OUT DOTS
520 FOR I=1 TO 8
530 FOR J=1 TO 2
540 BYTE=POS(HEX$,SEG$(C$,2*I+J-2,1),1)-1
550 FOR K=1 TO 4
560 P=2^(4-K)
570 B=INT(BYTE/P)
580 BYTE=BYTE-B*P
590 A(I,4*J+K-4)=B
600 REM
610 REM      ***** AND PRINT DOTS AS '*' OR " "
620 REM
630 PRINT CHR$(32+10*B);
640 PRINT #1:CHR$(32+10*B);
650 NEXT K
660 NEXT J
670 PRINT
680 PRINT #1:LF$
690 NEXT I
700 PRINT :
710 PRINT #1:LF$:LF$
720 REM
730 REM      ***** GRAPHICS DOT-COLUMNS FOR PRINTER
740 G$=""
750 FOR J=1 TO 8
760 K=128
770 FOR I=1 TO 7
780 K=K+A(I,J)*2^(I-1)
790 NEXT I
800 G$=G$%CHR$(K)
810 NEXT J
820 RETURN

```

```

      ***
     *  *  *
    *  *  *  *
   *  *  *  *  *
  *  *  *  *  *
 *  *  *  *  *
*  *  *  *  *

```

```

 *  *  *  *  *
*  *  *  *  *
 *  *  *  *  *
  *  *  *  *  *
   *  *  *  *  *
    *  *  *  *  *
     *  *  *  *  *

```

```

* * * * * * * * * * * * * *

```

# ASCII & CONTROL CODES

Add Column & Row Numbers to Get ASCII Value

## Decimal values

	0	1	2	3	4	5	6	7	8	9
30					"	#	\$	%	&	'
40	(	)	*	+	,	-	.	/	0	1
50	2	3	4	5	6	7	8	9	:	;
60	<	=	>	?	@	A	B	C	D	E
70	F	G	H	I	J	K	L	M	N	O
80	P	Q	R	S	T	U	V	W	X	Y
90	Z	[	\	]	^	_	`	a	b	c
100	d	e	f	g	h	i	j	k	l	m
110	n	o	p	q	r	s	t	u	v	w
120	x	y	z	(		)	~			
160	à	á	â	ã	ä	å	æ	ç	è	é
170	ê	ë	ì	í	î	ï	ä	å	ö	ø
180	ù	ú	û	ü	ý	z	£	¢	§	↑
190	+	→								

## Hexadecimal values

	0	1	2	3	4	5	6	7	8	9	A	B	C	D	E	F
20		!		#	\$	%	&	'	(	)	*	+	,	-	.	/
30	0	1	2	3	4	5	6	7	8	9		;	<	=	>	?
40	@	A	B	C	D	E	F	G	H	I	J	K	L	M	N	O
50	P	Q	R	S	T	U	V	W	X	Y	Z	[	\	]	^	_
60	`	a	b	c	d	e	f	g	h	i	j	k	l	m	n	o
70	p	q	r	s	t	u	v	w	x	y	z	(		)	~	
A0	à	á	â	ã	ä	å	æ	ç	è	é	ê	ë	ì	í	î	ï
B0	ä	å	ö	ø	ù	ú	û	ü	ý	z	£	¢	§	↑	↓	+ →

## Control Codes

ASCII	Decimal	Keyboard	Function
LF	10	CTRL-J	Print and advance PaPer
CR	13	CTRL-M	Print and advance PaPer
DC4	20	CTRL-T	Print without PaPer advance
SO	14	CTRL-N	Start double sized characters
SI	15	CTRL-O	Start normal sized characters
POS	16	CTRL-P	Start Position code sequence
BS	8	CTRL-H	Start Graphics sequence
ESC	27	CTRL-.	Start dot Position code sequence
FS	28	CTRL-;	Start Graphics repeat sequence
SPC	32		Space

Note that you must have 8 data bits for keyboard entry

HOME COMPUTER

TEXAS INSTRUMENTS



# TI-99 ITALIAN USER CLUB

[WWW.TI99IUC.IT](http://WWW.TI99IUC.IT)

[INFO@TI99IUC.IT](mailto:INFO@TI99IUC.IT)

*- Scanning and Reworking by:  
TI99 Italian User Club in the year 2015.  
([info@ti99iuc.it](mailto:info@ti99iuc.it))*

*Downloaded from [www.ti99iuc.it](http://www.ti99iuc.it)*

---

---

---

---

---

---

**AXIOM<sup>®</sup>**

AXIOM CORPORATION

1014 Griswold Avenue • San Fernando, CA 91340  
Telephone: (818) 365-9521 • TWX: 910-496-1746